

MAYSER®
Polymer Electric

Miniature Safety Edges Safety and Convenience for innovative furniture

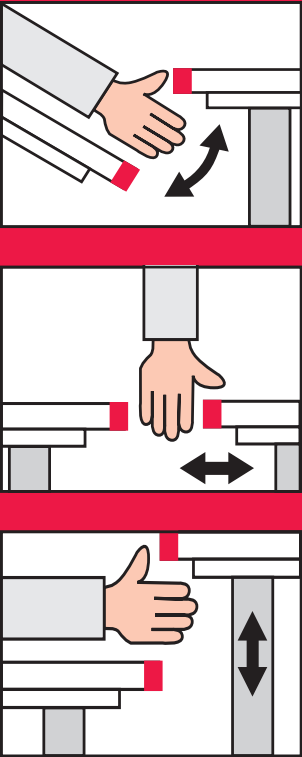

- safe
- convenient
- reliable

Mayser Miniature Safety Edges

Safety and Convenience

Protection of nipping and trapping points at the workplace, at home and at care centres.

- height-adjustable office workstations

- convenient adjustment of seating furniture

- automatic shelving systems

- electrically operated hospital and folding beds

- retractable television cabinets

- retractable screens

- height-adjustable washbasins and toilets

- power-operated kitchen units

- power-operated blackboards

In motion: higher demands on convenience and safety are clearing the way for power operated components in modern furniture.

Safety:

The advantages are obvious: office workstations can be conveniently adjusted for height or position. The seating position of armchairs and chairs changes at the push of a button.



Photo 1



Photo 2

Within the field of barrier-free living, kitchen units adapt easily to the needs of the physically disadvantaged.

All power-operated movements can, however lead to injuries or severe property damage.

To prevent this happening, we developed the Mayser Obstacle Detection System.

An electric Miniature Safety Edge at the point of danger reacts to the



Photo 3

slightest pressure and causes the motor of the moving element to come to an immediate halt.



Photo 4

Convenience:

The benefit of the Mayser Miniature Safety Edge goes beyond the question of safety: It can also be used as an elegant convenience switch. For example, mounted along the entire length of the kitchen worktop it serves as a continuous switch that can be actuated from any point to operate the worktop lighting.

Be it Obstacle Detection or a Convenience Switch: Mayser Miniature Safety Edges provide a maximum of safety and quality-of-life for future furniture technology.

Safety Edges: Solution for innovative furniture

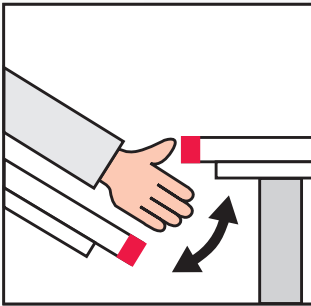

Safeguarding axial nipping points

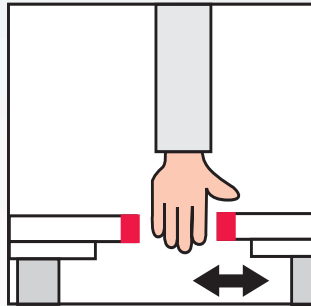

Safeguarding trapping points

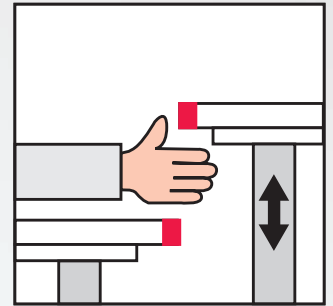

Safeguarding tangential nipping points

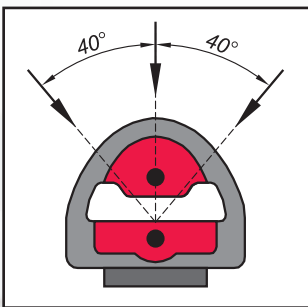

- The working principle of the Miniature Safety Edge is simple. If a small amount of pressure is applied to it, the two conductive surfaces (highlighted in red), held apart from each other, are short-circuited. In turn, a signal is transmitted to the connected evaluation electronics.

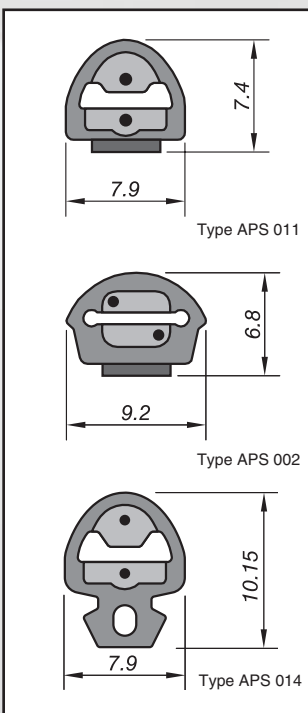

Dimensions given in mm

- The Safety Edge works principle according to the closed circuit current and is therefore reliable. Damage to the sensor is recognized and the danger movement is brought to a halt.
- In addition to the three standard types shown, customized profiles can also be produced.
- The Miniature Safety Edge is in its element wherever only very small travel distances are possible.
- Thanks to its small dimensions (see on the left) the Miniature Safety Edge can be easily integrated into its surroundings.

Innovative by tradition

Mayser Polymer Electric stands for safety. Thanks to many years of experience in tactile sensors we now have the largest possible know-how in safety systems at our disposal. Our products range from tactile sensors such as Safety Mats, Safety Edges and Safety Bumpers to non-contact protective devices and the latest industrial sensors.

As with all our products, the Miniature Safety Edge for furniture applications is an inhouse development. Opening up new areas of application is one of our main objectives.

So that we can continue to serve you in the future as a competent partner in matters relating to safety and convenience in power-operated furniture.



Supporting member of the trade corporation Barrierefrei Leben

Technical Data:

Special features

- thermoplastic elastomer
- customized TPE-covering
- environmentally friendly
- can be recycled

Electric operation conditions

- Voltage max. 24 V DC
- Current max. 10 mA / min. 1mA
- Contact transition resistance < 400 W (under load)
- Connecting cable

Ø 3,7 mm	Ø 3,4 mm
2x 0.25 mml	2x 0.25 mml
- Strand type

5	6
---	---

 according to IEC 60228

Degree of Protection

- IP65

Dimensional tolerances

Length according to ISO 3302 L2
Cross section according to ISO 3302 E2

Applied using acrylic foam adhesive

Peel strength	15 N/cm	
Stuck to:	with Primer	without Primer
ABS	+	-
Aluminium	+	+
Natural wood	-	-
Wood: varnished, with veneer or plastic-laminated	+	-
PA6	+	-
PA66	+	+
PE, HDPE	-	-
FMMA	+	+
PP, SAN	+	-
PS, CAB	-	-
PVC	+	+
Steel, stainless steel	+	+

Functional features

- Response angle: to 80° (depends on profile shape!)
- Actuation distance: ≤ 1,0 mm
- Actuation force: < 15 N (Test piece (rod): Ø 200 mm)
- Actuation force: < 8 N (Test piece (rod): Ø 4 mm)
- Switching operations: F=100 N >100 000 (Test piece (rod): Ø 10 mm)

Operating temperature:

- 25 °C to +80 °C
- 40 °C to +100 °C (short term)

Behaviour in fire

according to DIN 75200 40 mm/min

Test were carried out at room temperature 23 °C

Key to symbols:

- + = OK
- = not OK

MAYSER®

Mayser GmbH & Co. KG
Polymer Electric
Örlinger Str. 1-3
89073 Ulm
GERMANY
Tel.: +49 731 2061-0
Fax: +49 731 2061-222
www.mayser.de
E-Mail: info@mayser.de