

MAYSER®

Polymer Electric

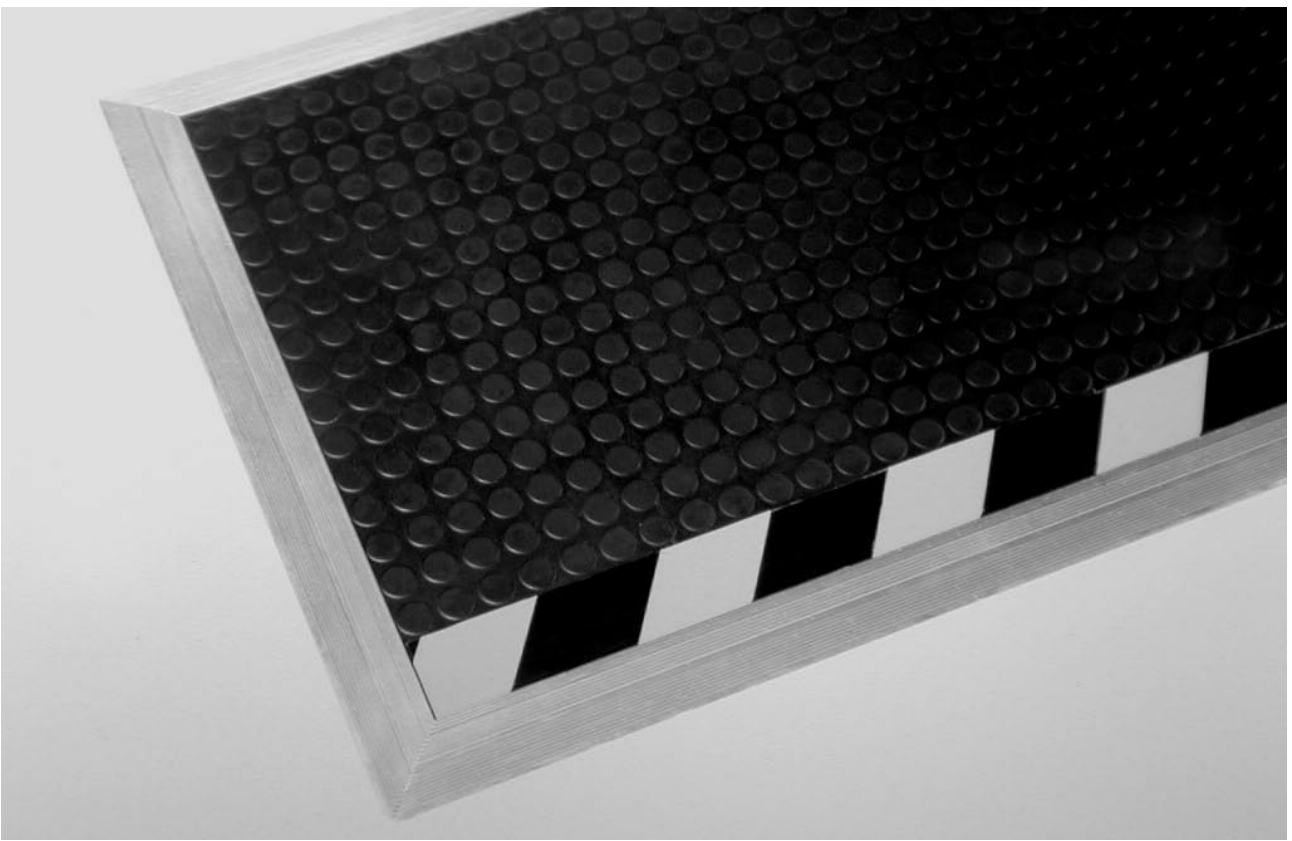

Installation Instructions



Safety Mats SM

MAYSER® GmbH & Co. KG
Polymer Electric
Örlinger Straße 1-3
89073 Ulm
GERMANY
Tel.: +49 731 2061-0
Fax: +49 731 2061-222
<http://www.mayser.com>
E-Mail: info@mayser.com

Contents

1	About these installation instructions	3
2	Safety	4
2.1	Intended use	4
2.2	Safety label on the product	4
2.3	Residual dangers	5
2.4	Applicable standards	5
3	Technical Data	6
4	Transport and storage	6
4.1	Packaging and transport	6
4.2	Storage	6
5	Installation	7
5.1	Preparing the installation site	7
5.2	Unpacking	8
5.3	Arranging the Safety Mats	9
5.4	Installing Z-profiles	10
5.5	Positioning the Safety Mats	11
5.6	Installing Ramp Edges AK 66	12
5.7	Installing two-part Ramp Edges AK 105 and AK 105/1	14
5.7.1	Installing lower sections of the ramp rails	14
5.7.2	Installing upper sections of the ramp rails	16
5.8	Laying cables	16
5.9	Testing	19
6	Maintenance and cleaning	20
7	Disposal	20

1 About these installation instructions

These installation instructions are part of the product.

Mayser Polymer Electric accepts no responsibility or warranty claims for damage and consequential damage due to failure to observe the installation instructions.

- ➔ Read installation instructions carefully before use.
- ➔ Keep installation instructions for the complete service life of the product.
- ➔ Pass installation instructions on to every subsequent owner or user of the product.
- ➔ Add any supplement received from the manufacturer to the installation instructions.

Validity

These installation instructions are only valid for the products specified on the title page.

Target group

The target group of these installation instructions are operators and trained specialist personnel who are familiar with installation and commissioning.

Other applicable documents



- ➔ The following documents are to be observed in addition to the installation instructions:
 - drawing of the Safety Mat system (optional)
 - wiring diagram (optional)
 - operating instructions of the Control Unit used

Symbols used

Symbol	Meaning
➔ ...	Action with one step or with more than one step where the order is not relevant.
1. ... 2. ... 3. ...	Action with more than one step where the order is relevant.
• ...	Bullets first level
- ...	Bullets second level
(see chapter 1, pg. 3)	Cross-reference

Tab. 1-1: Other symbols

Danger symbols and information

Symbol	Meaning
<p>DANGER</p> 	Immediate danger leading to death or serious injury.
<p>CAUTION</p> 	Possible danger which may lead to slight injury or damage to property.
	Information on easier or safer working practices.

Tab. 1-2: Danger symbols and information

2 Safety

2.1 Intended use

The product is designed as a pressure-sensitive protective device for protecting areas, which is activated when stepped on by persons with a weight of more than 20 kg.

2.2 Safety label on the product

A label is attached to the underside of every Safety Mat with symbols which warn against damage to the Safety Mat. In addition, you will find our contact address there.

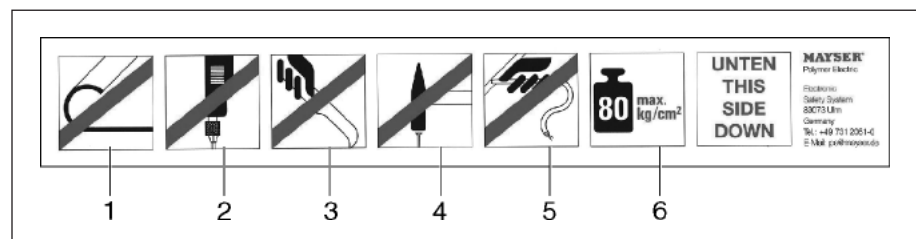

Fig. 2-1: Safety label on the product

- 1 Do not allow Safety Mat to bend or sag
- 2 Do not make holes or cut-outs in the Safety Mat
- 3 Do not cut Safety Mat
- 4 Do not hammer or screw any objects (nails, screws etc.) into the Safety Mat
- 5 Do not use the cable as a carrying handle
- 6 The maximum load bearing capacity of the Safety Mat is 80 kg/cm²

2.3 Residual dangers

Non-sensitive edges

The edges of the Safety Mats are not sensitive (40 mm on the cable exit side, 10 mm on all other sides). When non-sensitive areas are stepped on, the protective function of the Safety Mat is not active.

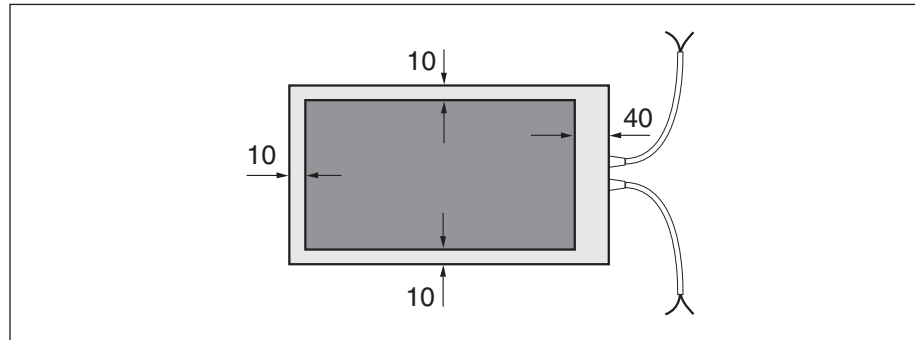

Fig. 2-2: Non-sensitive edges

- ➔ Install Safety Mats wherever possible in direct contact with the source of danger.
- ➔ When installing more than one Safety Mat, ensure that cable exit sides always remain clear.
- ➔ At the danger source, place a covering over parts (surfaces, cross struts etc.) which could be used as a tread.
- ➔ When positioning the Safety Mats, observe the standard EN 999 „The positioning of safety equipment in respect of approach speeds of parts of the human body“.

Replacement parts

When using non-OEM replacement parts, the safety of the Safety Mats may be impaired.

- ➔ Only use OEM replacement parts from Mayser.

2.4 Applicable standards

The construction type of the product complies with the EC machinery directive 98/37/EC and EMC directive 2004/108/EC.

Applicable standards:

- EN 1760-1 “Safety of machinery – Pressure-sensitive protective devices – Part 1: pressure-sensitive mats and pressure-sensitive floors”
- EN 954 “Safety of machinery – Safety-related parts of controls”
- EN 61000-6-2 “Electro-magnetic compatibility (EMC) – Part 6-2: generic immunity standard for industrial areas”
- IEC 61508 “Functional safety of safety-related electrical/ electronic/ programmable electronic systems”

These installation instructions were prepared in compliance with DIN EN 62079 “Preparation of instructions – structuring, content and presentation”.

3 Technical Data

Protection class of the Safety Mats	IP65
Actuation forces for signal triggering	in accordance with EN 1760-1
Error behaviour	EN 954 Category 3
Safety integrity level SIL2	SIL2 in accordance with IEC 61508
Operating temperature of individual Safety Mats	-5 °C to +55 °C
Operating temperature of combined Safety Mats	+5 °C to +55 °C
Storage temperature	-20 °C to +55 °C
Static load	max. 800 N/cm ²
Weight	15 mm: 17.4 kg/m ² 19 mm: 24.0 kg/m ²

Tab. 3-1: Technical data of the sensors W and BK

Type plate

A type plate is attached to the cable exit on the underside of the Safety Mat for identification of the Safety Mat type. In the event of enquiries, have the specified information to hand.

4 Transport and storage

4.1 Packaging and transport

The Safety Mats are packed in wooden crates (max. 10 Safety Mats per crate) and can be transported to the installation site with a crane or lifting truck. Depending on the scope of supply, the installation accessories are either included with the Safety Mats or packed separately.

DANGER



Danger of injury due to components falling!

- ➔ Only use tested, suitable load bearing equipment.
- ➔ Use appropriate load securing devices (e.g. transport belts, anti-slipping devices).
- ➔ Do not stand under suspended loads.

4.2 Storage

- ➔ Store Safety Mats in the original packaging in a dry place.
- ➔ Note and observe storage temperature in accordance with the technical data.

5 Installation

Overview

Install Safety Mats in the following order:

1. Prepare the installation site
2. Unpack Safety Mats and accessories.
3. Lay out Safety Mats.
4. Install Z-profiles.
5. Align Safety Mats flush with the installed Z-profiles.
6. Fix Safety Mats with fixing rails:
 - Z-profiles on sides which are directly adjacent to machine parts or walls
 - ramp rails on sides which are freely accessible
7. Lay cables.
8. Test function.

5.1 Preparing the installation site

DANGER



Danger of injury due to equipment and parts in the vicinity of the installation site (possible electrocution, crushing danger)!

- ➔ Disconnect all equipment and voltage-carrying parts in the immediate vicinity of the installation site from the power supply and secure against being switched on again (see relevant operating instructions).
- ➔ Check that the equipment or parts are disconnected from the power supply.

➔ Preparing the installation surface:

- Create level surface where necessary (e.g. screed). There must not be any bumps or holes with a diameter of more than 20 mm.
- Remove dirt particles.
- Ensure that the surface is dry.

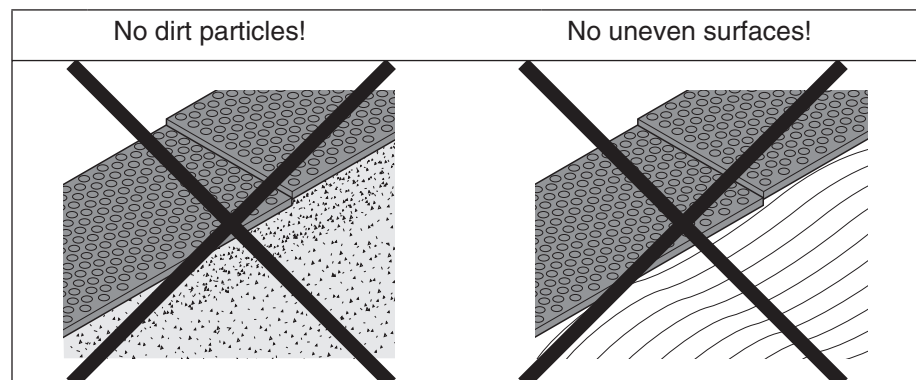

Fig. 5-1: Examples of unsuitable installation surface

➔ Provide necessary tools

5.2 Unpacking

CAUTION



Damage to property due to incorrect handling!

Safety Mats can be damaged by bending or due to the effects of sharp objects.

- ➔ Always transport Safety Mats upright to prevent sagging.
- ➔ Safety Mats are always to be transported by two persons.
- ➔ Only place Safety Mats on a level, dirt-free, dry surface.
- ➔ Do not use the connection cable of the Safety Mats as a carrying handle.

1. Check that the contents of the packaging are undamaged.
2. Ensure that the ramp rails and Z-profiles supplied correspond with the overall height of the Safety Mat. See following table.

	Overall height	
	15 mm	19 mm
Z-profile	Z 	Z/1
Ramp Edges	AK 66 oder AK 105 	AK 105/1

Tab. 5-1: Z-profiles and Ramp Edges for various overall heights of Safety Mats (dimensions in mm)

5.3 Laying out the Safety Mats

1. Approximately arrange Safety Mats (possibly in accordance with the drawing of the Safety Mat system). Observe the following:
 - lay the Safety Mats in such a way that the structured side is face up or the type plate is face down.
 - lay Safety Mats in such a way that the cable exits are facing in the direction of the ramp rails.

Check the resistance between the two wire ends of the cable of each Safety Mat with an ohmmeter.

The measured resistance must have the following value:

- Sensor W: $1.2 \text{ k}\Omega \pm 2\%$
- Sensor BK: $> 1 \text{ M}\Omega$



Ensure that no short circuit can ensue between the strands of the second cable!

3. Arrange all fixing rails (ramp rails, Z-profiles) at a short distance from their final position in order to arrange the Safety Mats.

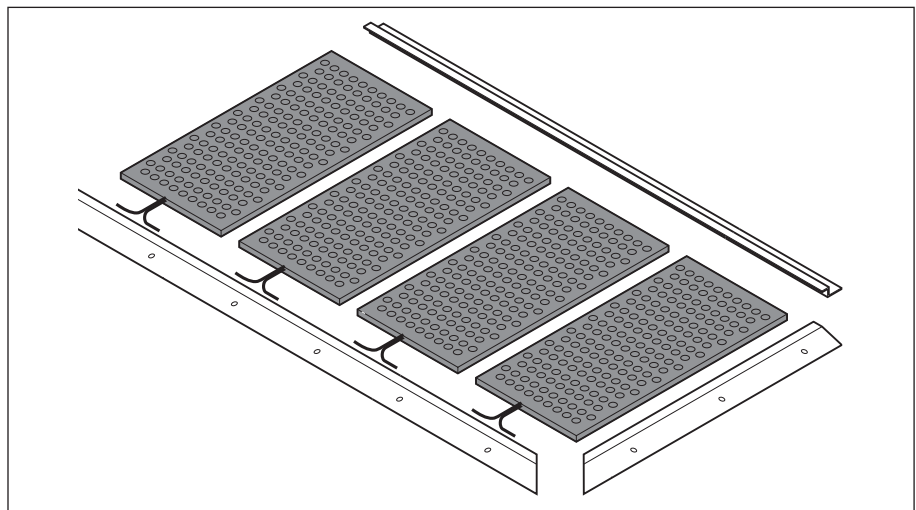

Fig. 5-2: Arrange Safety Mats and fixing rails

5.4 Installing Z-profiles

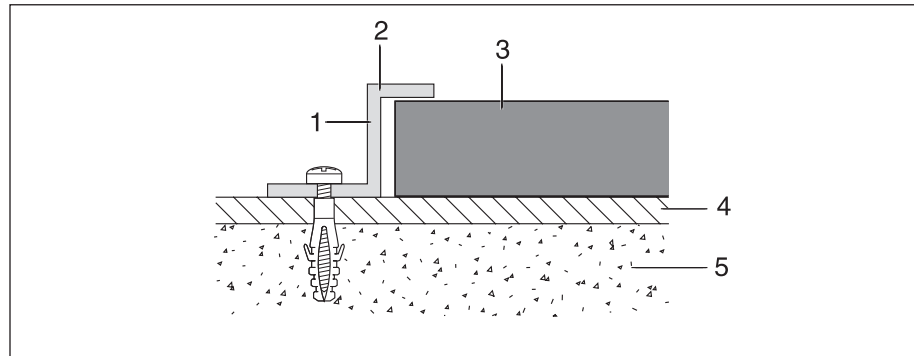

Fig. 5-3: Installation cross-section for Z-profile

- | | |
|--------------|---------------|
| 1 Stop ridge | 4 Plant floor |
| 2 Z-profile | 5 Screed |
| 3 Safety Mat | |

CAUTION



Danger of tripping!

There is a risk of tripping on a side which is bordered by a Z-profile.

- ➔ Only install Z-profile on sides directly adjacent to machine parts or walls.

1. Draw line on surface along which Z-profiles are to be installed.
2. Position Safety Mats on line.
3. Place Z-profiles on the Safety Mat edges:
 - For installation of the first side: Push stop ridges of the Z-profiles against the Safety Mat edges.
 - When installing further sides: Mark Safety Mat edge and align Z-profiles (see Fig. 5-6, pg. 12).

The Safety Mat edge must be covered by the upper ridge of the Z-profiles (see Fig. 5-3, pg. 10).

4. Mark corners of the Safety Mat system on the Z-profiles.
5. Saw off Z-profiles at the places marked and cut to size accordingly.

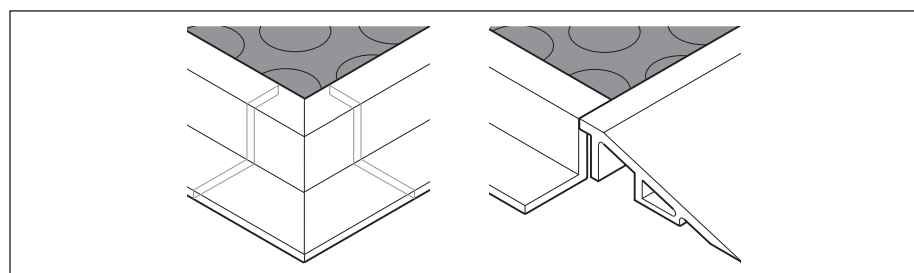

Fig. 5-4: Cut Z-profiles to size for the corners of the Safety Mat system

6. Where necessary, drill holes in the stop ridges of the Z-profiles for cable exits.

7. Remove burrs on holes and interfaces.
8. Re-position Z-profiles:
 - For installation of the first side: Align Z-profiles on the line marked on the installation surface.
 - When installing further sides: Align Z-profiles along the marking on the Safety Mat edge (see Fig. 5-6, pg. 12)
9. Fix Z-profiles to installation surface with plugs (Ø 6 mm) and screws (Ø 4 mm, length: min. 40 mm) at intervals of 50 to 70 cm.
10. Remove drilling dust (e.g. with a vacuum cleaner), as otherwise the drilling dust could get under the Safety Mats and the ramp rails and lead to unevenness.

5.5 Positioning the Safety Mats

1. Push Safety Mats against the installed Z-profiles.
 - For installation of the first side: Push Safety Mats against the stop ridges of the Z-profiles.
 - When installing further sides: Mark Safety Mat edge and align Z-profiles (see Fig. 5-6, pg. 12).
2. Place all Safety Mats edge to edge. Observe the following:
 - Arrange all cable exit sides in the same direction.
 - Ensure that the distances between the Safety Mats are not more than 1 mm.
 - Do not compress or bend Safety Mats.
 - Ensure that there are no gradings on the Safety Mat edges.

5.6 Installing Ramp Edges AK 66

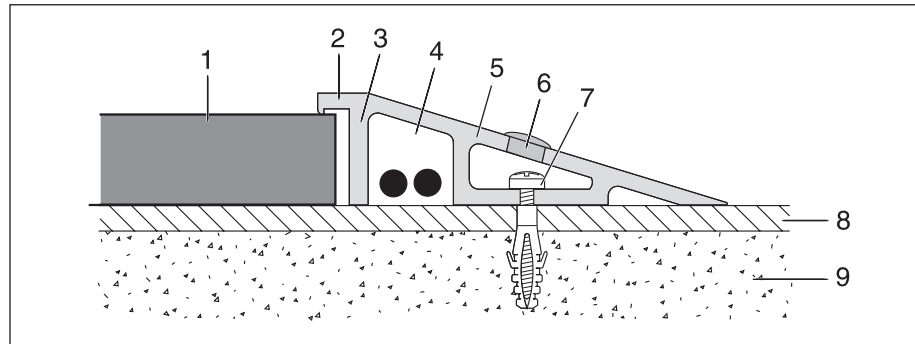

Fig. 5-5: Installation cross-section for Ramp Edge AK 66

- | | |
|---------------------------------|----------------|
| 1 Safety Mat | 6 Sealing plug |
| 2 Cover ridge | 7 Fixing screw |
| 3 Stop ridge | 8 Plant floor |
| 4 Cable conduit (max. 2 cables) | 9 Screed |
| 5 Ramp Edge AK 56 | |



Due to heat expansion of the Safety Mats, the ramp rails must be installed at room temperature in such a way that an air gap of approx. 3 mm wide exists between the edge of the Safety Mat and the stop ridge (3) of the ramp rail, as otherwise the Safety Mats may arch at high temperatures.

1. Mark the Safety Mats, e.g. with a ballpoint pen, at intervals of 2 mm from the outer edges of the Safety Mat system (see Fig. 5-6, pg. 12).

The ramp rails are aligned with these marks so that an air gap of 3 mm remains between the edge of the Safety Mat and the stop ridge of the ramp rails or cable conduits.

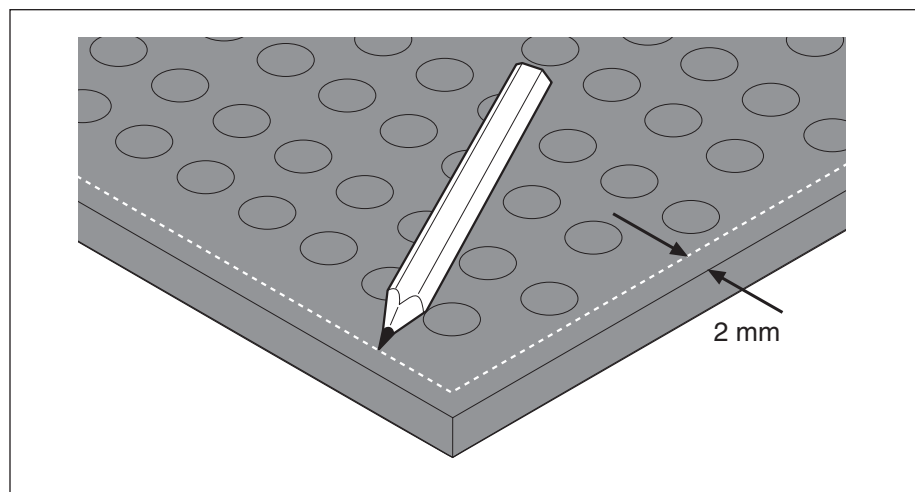

Fig. 5-6: Position the Safety Mats

2. Place the ramp rails against the Safety Mats and align the edges of the cover ridge with the marks.
3. Mark corners of the Safety Mat system and if necessary cable exits on the ramp rails.
4. Saw off ramp rails at the places marked and cut to size accordingly.

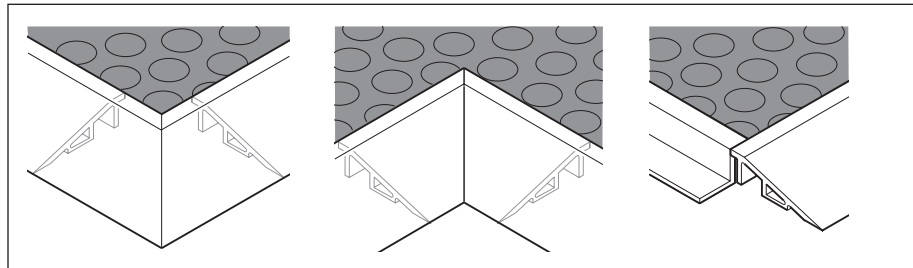

Fig. 5-7: Cut ramp rails on the corners of the Safety Mat system to size

5. If necessary, mark cable exits on the stop ridges and cut out as follows:
 - Saw right into the stop ridge at every point marked at intervals of approx. 10 mm.
 - Break off the piece between the saw cuts with pliers.
6. Remove burrs on edges.
7. Place the ramp rails against the Safety Mats and align the edges of the cover ridge with the marks.
8. Drill holes in ramp rails and installation surface at intervals of 50 to 70 cm so that the ramp rails can be fixed to the installation surface with plugs (Ø 6 mm) and screws (Ø 4.5 mm, length: min. 40 mm).
9. Remove burrs on holes.
10. Remove ramp rails.
11. Clean ramp rails, installation surface and holes of drilling dust (e.g. with a vacuum cleaner), as otherwise the drilling dust could get under the Safety Mats and the ramp rails and lead to unevenness.
12. Insert plugs (Ø 6 mm) into the holes in the installation surface.
13. Place ramp rails against the Safety Mats again.
14. Thread cables through the cable exits and cable conduit.
15. Align the edges of the cover ridges with the markings on the Safety Mats.
16. Fix ramp rails to installation surface with screws (Ø 4.5 mm, length: min. 40 mm).
17. Push sealing plugs (optional) into the graduated bore holes.

5.7 Installing two-part Ramp Edges AK 105 and AK 105/1

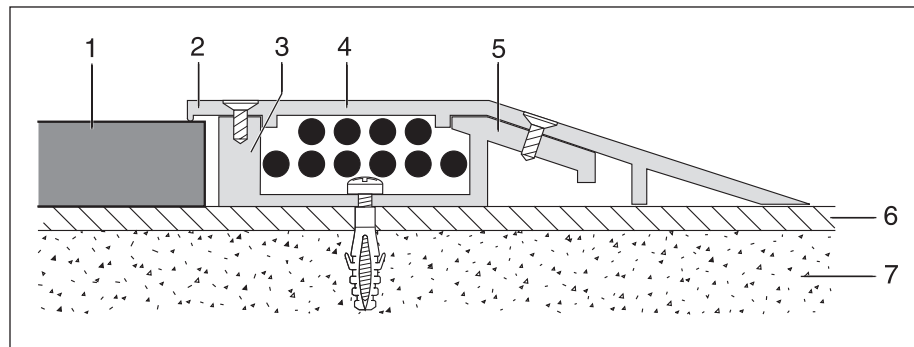

Fig. 5-8: Installation cross-section for Ramp Edges AK 105 and AK 105/1

- | | |
|---------------------------|---|
| 1 Safety Mat | 5 Lower section ramp rail (with cable conduit for max. 10 cables) |
| 2 Cover ridge | 6 Plant floor |
| 3 Stop ridge | 7 Screed |
| 4 Upper section ramp rail | |



Due to heat expansion of the Safety Mats, the ramp rails must be installed at room temperature in such a way that an air gap of approx. 3 mm wide exists between the edge of the Safety Mat and the stop ridge on the lower section of the ramp rail, as otherwise the Safety Mats may arch at high temperatures.

5.7.1 Installing lower sections of the ramp rails

1. Place lower sections against the Safety Mats at a distance of 3 mm.
2. Mark corners of the Safety Mat system and if necessary cable exits on the lower sections.
3. Saw off lower sections at the places marked and cut to size accordingly.

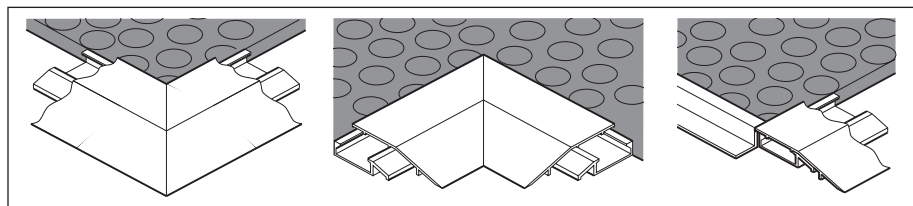

Fig. 5-9: Cut lower sections of the ramp rails on the corners of the Safety Mat system to size

4. If necessary, mark cable exits on the stop ridges and cut out as follows:
 - Saw right into the stop ridge twice at the points marked at a distance of approx. 10 mm.
 - Break off the piece between the saw cuts with pliers.
5. Remove burrs on edges.
6. Place cut lower sections against the Safety Mats again with a 3 mm gap.
7. Drill holes in lower sections and installation surface at intervals of 50 to

70 cm so that the lower sections can be fixed to the installation surface with plugs (Ø 6 mm) and screws (Ø 4.5 mm, length: min. 40 mm).

8. Remove lower sections.
9. Remove burrs on holes.

Clean lower sections, installation surface and holes of drilling dust (e.g. with a vacuum cleaner), as otherwise the drilling dust could get under the Safety Mats and the ramp rails and lead to unevenness.

11. Insert plugs (Ø 6 mm) into the holes in the installation surface.
12. Place lower sections against the Safety Mats again.
13. Thread cables through the cable exits and lower sections.
14. Fix lower sections to installation surface with screws (Ø 4.5 mm, length: min. 40 mm).

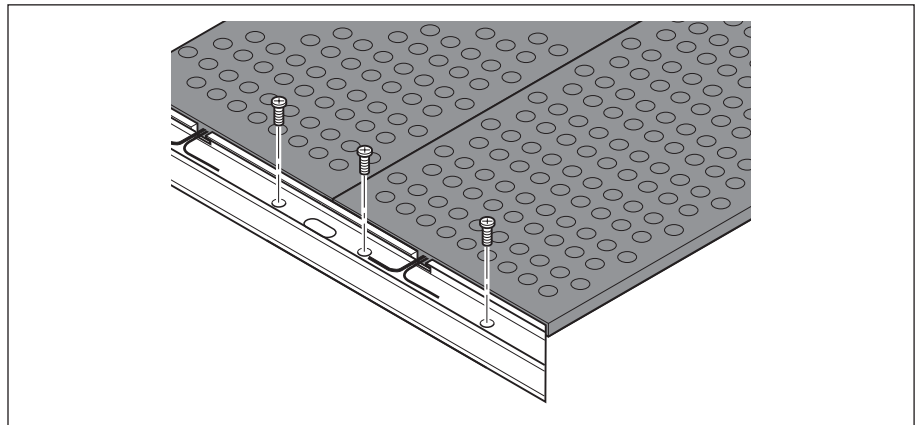

Fig. 5-10: Fix lower sections of the ramp rails to the installation surface

5.7.2 Installing upper sections of the ramp rails

1. Place upper sections of the ramp rails onto the installed lower sections.
2. Mark corners of the Safety Mat system on the upper sections.
3. Saw off upper sections at the points marked.
4. Remove burrs on edges.
5. Place upper sections on lower sections again.
6. Screw upper sections onto lower sections with thread rolling screws (M6).

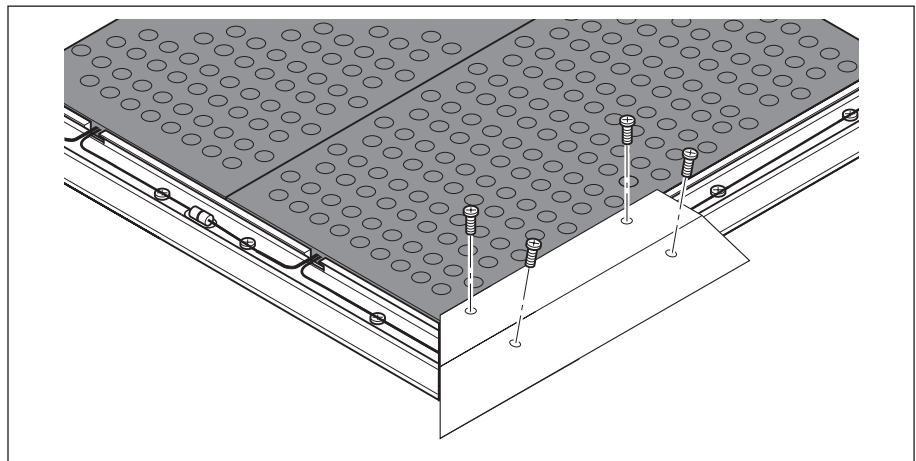

Fig. 5-11: Screw on upper sections of ramp rails

5.8 Laying cables

The type of cabling depends on the operation principle of your system.

1. Wire up Safety Mats in accordance with wiring diagram (optional) or in accordance with the wiring technologies described below. Observe the following:
 - Connect the wire ends of the Safety Mats in accordance with the colour coding
 - If no plugs and sockets are available (optional), insulate soldering points and seal with heat-shrinkable sleeves
 - Wire each zone separately and route the cables to a separate Control Unit.

CAUTION



Damage to cables due to incorrect laying!

- ➔ Do not pinch or bend cables.

2. Lay cables and route to Control Unit.

The multi-functional cut-out on the cable exit of the Safety Mat also allows the cable to be laid downwards.

Key to the following wiring diagrams:

- BK Safety Mat with two-sided cables as feed-through sensors or for connection of an external monitoring resistor
- W Safety Mat with integrated monitoring resistor
- SG Safety Control Unit
- D Sub-distribution with series terminals
- R Resistor for functional monitoring of the system
(1.2 kΩ ± 2%)

Colour coding:

- bl blue
- br brown
- rt red
- sw black
- ws white

**Safety Mats BK:
2-wire technology**

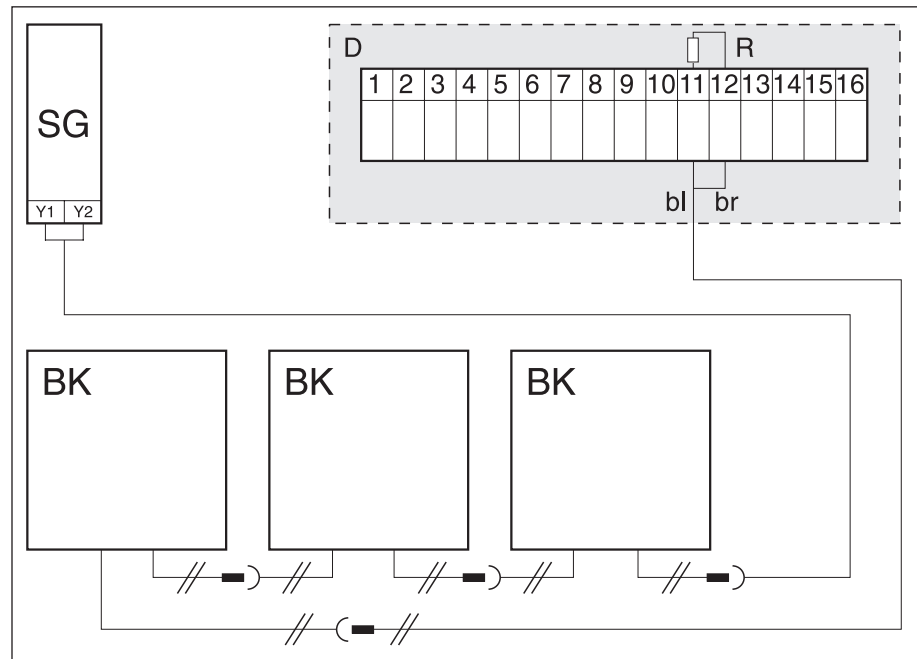

Fig. 5-12: Wiring of the Safety Mats BK for 2-wire technology

**Safety Mats BK:
2-wire technology with
terminal connector
(optional)**

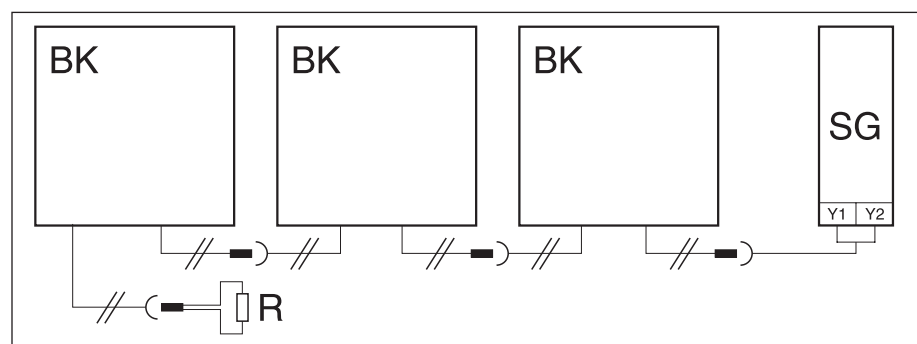

Fig. 5-13: Wiring of Safety Mats BK for 2-wire technology with optional terminal connector, in which the resistor R is integrated

**Safety Mats W and BK:
2-wire technology
wired straight to the
Control Unit**

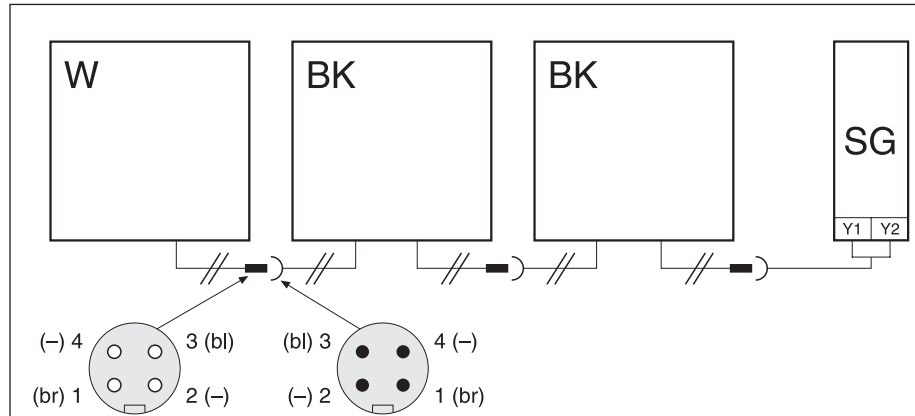

Fig. 5-14: Wiring of the Safety Mats W and BK for 2-wire technology

**Safety Mats W and BK:
2-wire technology wired
via sub-distribution
system**

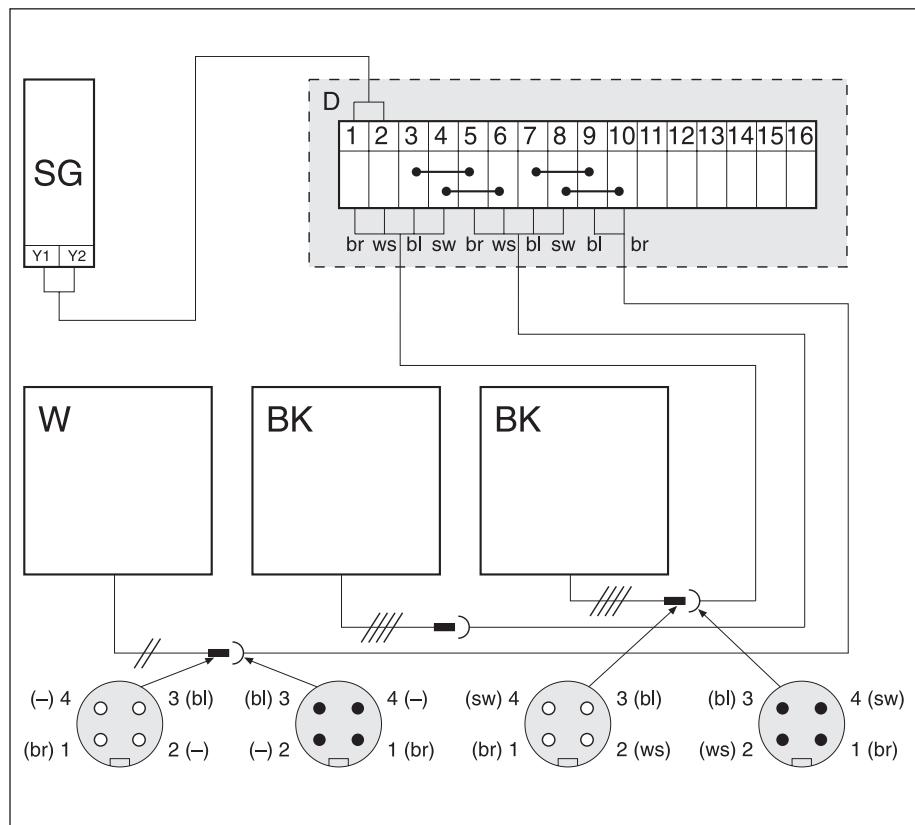

Fig. 5-15: Wiring of the Safety Mats for 2-wire technology

**Safety Mats BK:
4-wire technology**

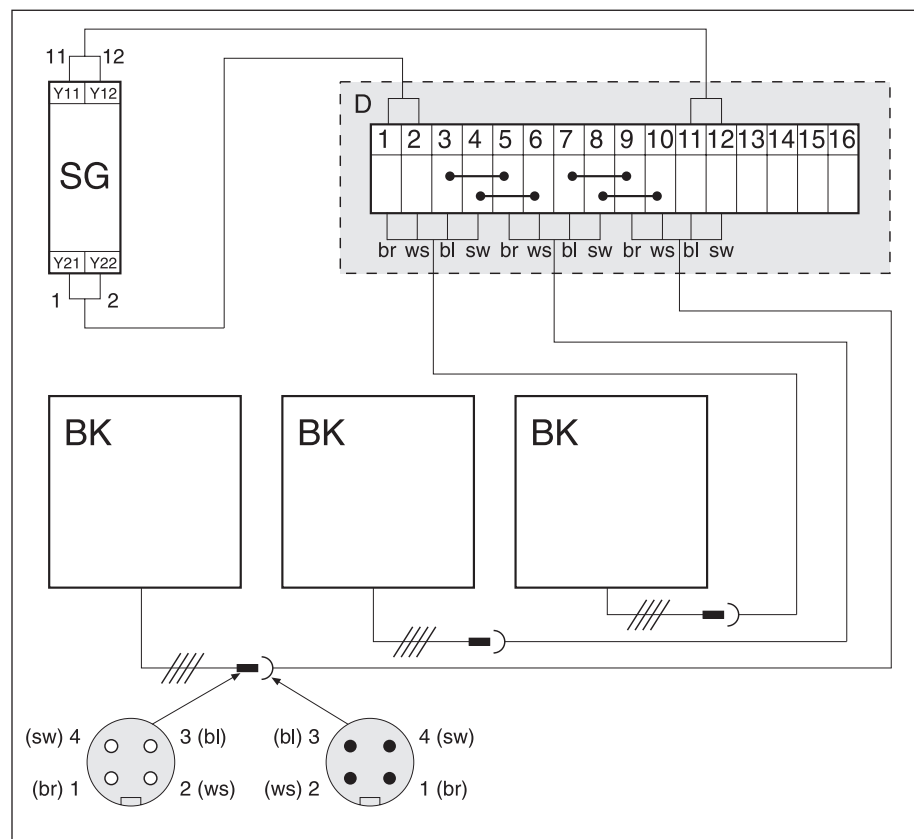

Fig. 5-16: Wiring of the Safety Mats BK for 4-wire technology

5.9 Testing

Carry out the following actions for every cable of the Safety Mat system:

1. Set ohmmeter for measuring in a high resistance range.
2. Connect ohmmeter to the two wires of the cable.
3. Measure the electrical resistance between the wire ends with activated and non-activated Safety Mat.

The measured resistance must have the following values:

- loaded (activated) Safety Mat system: < 150 Ω
- not loaded (not activated) Safety Mat system:
 - Sensor BK: > 1 MΩ
 - Sensor W: 1.2 kΩ ± 5%

Test failed?

If the resistance measurement does not produce the necessary values, this may have the following causes:

- The cables of the individual Safety Mats are incorrectly connected
- The cables are bent or damaged
- The Safety Mats are not lying flat on the floor

6 Maintenance and cleaning

The Safety Mats are virtually maintenance-free.

- ➔ Clean the surface of the Safety Mats at regular intervals using mild detergents.
- ➔ After cleaning, remove any remaining fluid.

Regular inspection

- ➔ Inspect Safety Mat surfaces for damage at regular intervals.
- ➔ Check safety function of the Safety Mats at regular intervals.

7 Disposal

The products included in the scope of supply contain the following materials:

Safety Mats

- plastics
- graphite (interior of Safety Mat, depending on type)
- aluminium (interior of Safety Mat, depending on type)
- copper (interior of Safety Mat, cables)

Installation accessories

- steel (screws)
- aluminium (ramp rails, Z-profiles, cable conduits)
- plastics (connecting elements, rubber bungs)

Packaging

- wood, cardboard, plastics

The following is to be observed when disposing of these materials:

- ➔ Observe all relevant national disposal regulations and statutory conditions.
- ➔ Provide the material list given above when using a disposal company.
- ➔ Recycle or dispose of materials in an environmentally friendly way.