

Control Unit SG-RSV 2X9

Operating Instructions



Control Unit

in accordance with EN 50155 and EN 50121-3-2
class S2 in accordance with EN 50155
EN 954 Category 2
EN 50129 SIL1
for sensors with monitoring resistor 1k Ω

These operating instruction apply to the following control units:

1004156	SG-RSV 209 2s	24 V =
1004155	SG-RSV 209 8s	24 V =
1004093	SG-RSV 209 12s	24 V =
1004764	SG-RSV 219 2s	110 V =
1004765	SG-RSV 219 8s	110 V =
1004091	SG-RSV 219 12s	110 V =

Control system

The Control Unit has two monitoring circuits which operate the output relays. The electronics monitor the electrical resistance of the connected sensors which have a defined zero signal current.

When the sensors are not activated (normal operating conditions), the output relays are energised.

If a break occurs in the supply line between the sensor and the control unit, the relays "fault" and "monitoring loop" are deactivated.

Depending on the internal train signals and the sensors, the relays "activated" and "monitoring loop" are deactivated.

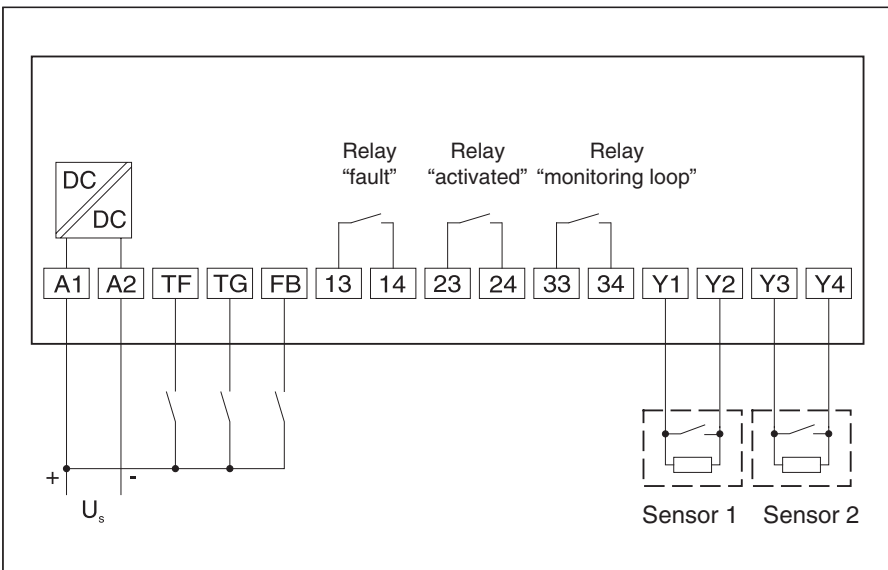

Enclosure

W x H x D (mm)	45 x 75 x 108
Protection class	IP20
Plug connection	2x 8-pin
Cable clamps	max. 2.5 mm ²
Weight	approx. 195 g

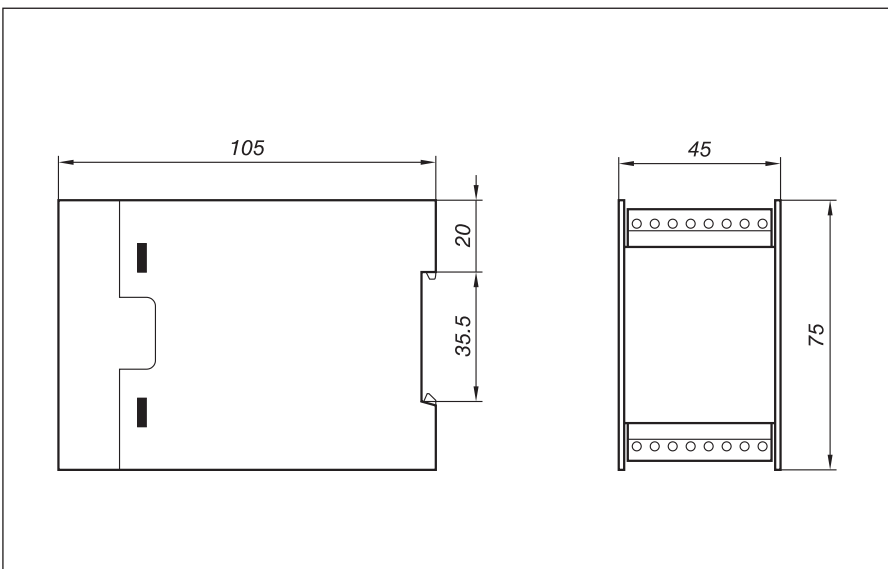

Parts supplied

- **Control Unit**
Enclosure with electronics module and plug connections with lift-up lock release.
- **Operating Instructions**

Control Unit SG-RSV 2X9

IMPORTANT NOTES!

To ensure correct and safe operation of the unit, it must be properly transported and stored, properly installed and commissioned, and operated in accordance with its intended use. Only persons familiar with the installation, commissioning and operation, and with the corresponding qualifications to prove their skills, may work on the units. They must observe the contents of these instructions, the information given on the type plate of the unit and the relevant safety regulations for the installation and operation of electrical systems.

Please read!

This unit is designed and tested in accordance with EN 50155 and EN 50121-3-2 and left the factory in a perfectly safe condition. To maintain this condition, you must observe the safety regulations marked WARNING! in these operating instructions. Failure to observe the safety regulations can lead to death, injury to personnel, or damage to the unit and other systems and equipment. Should the information given in these operating instructions be inadequate in any way, please contact your local technical centre, subsidiary or representative.

When using the device outside the European Union, you must observe the relevant regulations valid for the country of use.

Technical Data

Connecting voltage U_s

SG-RSV 209	DC 24 V (S2)
SG-RSV 219	DC 110 V (S2)
SG-RSV 279	DC 72 V (S2)
Voltage tolerance	-30% to +30%
Nominal frequency	-
Frequency tolerance	-
Power consumption	< 3 W

Times

Follow-through time t_N	200 ms
Extension time t_D	0.1 to 2.5 s factory setting: 200 ms
Active time t_A	2 to 15 s factory setting: 2 s, 8 s or 12 s

Sensor voltage

max. DC 12 V

Switching thresholds at +23 °C

	Y1 / Y2	Y3 / Y4
activated	< 430 Ohm	< 430 Ohm
cable break	> 2k5	>2k5

Status sensor voltage

max. U_s

Relay data

	AC 12	DC 12
Switching current	max. 1 A	max. 1 A
Switching voltage	max. AC 250 V	max. DC 150 V
Breaking capacity	max. 250 W (AC 12)	max. 30 W (DC 12)
Switching operations		
mechanical	> 2×10^7	
electrical	> 1×10^5 (AC 250 V / 1 A)	

Operating conditions

Perm. ambient temperature	-30 °C to +70 °C
Rel. humidity	max. 95%
Vibration fatigue limit	
Frequency range	5 to 150 Hz
Excursion amplitude	± 2 mm
Acceleration amplitude	5 g in all 3 levels

Important notes:

- **Supply voltage**
must correspond to the connecting voltage U_s on the type plate.
- **Permissible temperature range**
When installing in switch cabinet, maintain sufficient distance from heat sources (min. 2 cm).
- **Fusing of the relay contacts**
due to risk of welding, externally with 1.0 A inert.

Note:

When switching inductive loads the user must be fitted out with spark absorbers.

Installation and Operation

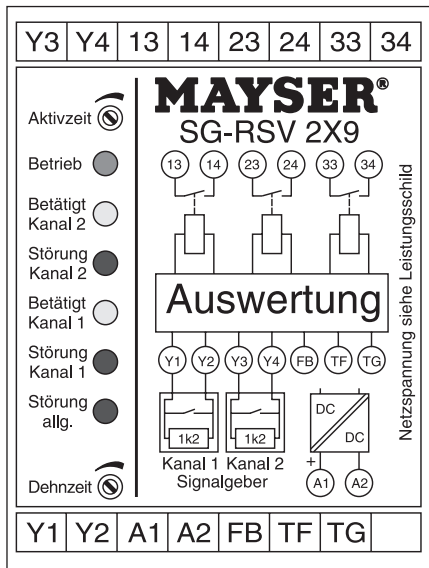

Installation

The enclosure of the control unit can be mounted in any position:
 - on a 35 mm standard rail EN 50022
 Wiring is connected to the cable clamps of the plug connections:

Sensor 1	Y1	Y2
Sensor 2	Y3	Y4
Supply voltage	A1	A2
Relay "fault"	13	14
Relay "activated"	23	24
Relay "monitoring loop"	33	34
Internal train signal "Door closed"	TG	
Internal train signal "Door release"	TF	
Internal train signal "Move command"	FB	

WARNING!

Do not release terminals or connect plug connections with power on.

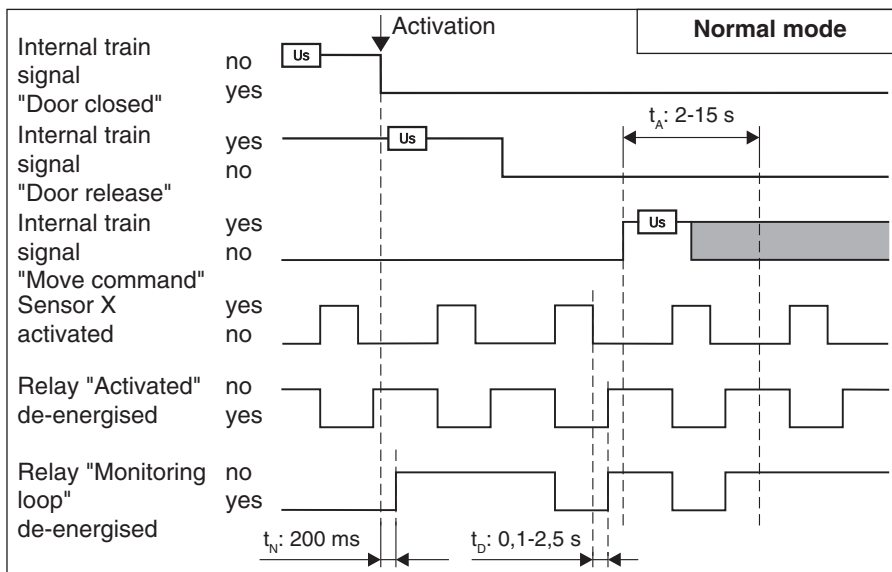

Commissioning

After connecting up sensors, relay contacts and power, carry out a function test in the following order:

Basic settings

- Two times can be varied on the unit:
 - Active time t_A : factory setting 2 s, 8 s or 12 s
 - Extension time t_D : factory setting 200 ms

Sensor not activated

- relay "activated" is energised
- relay "fault" is energised
- relay "monitoring loop" is energised (depending on internal train signals)

Sensor activated

- LED "Betätigt Kanal X" (activated channel X) lights up
- relay "activated" is de-energised
- relay "monitoring loop" is de-energised (depending on internal train signals)

Sensor disconnected

- LED "Störung Kanal X" (fault channel X) lights up
- relay "fault" is de-energised
- relay "monitoring loop" is de-energised

Note:

Restart normal operation by changing the internal train signals "Door closed" and/or "Door release".

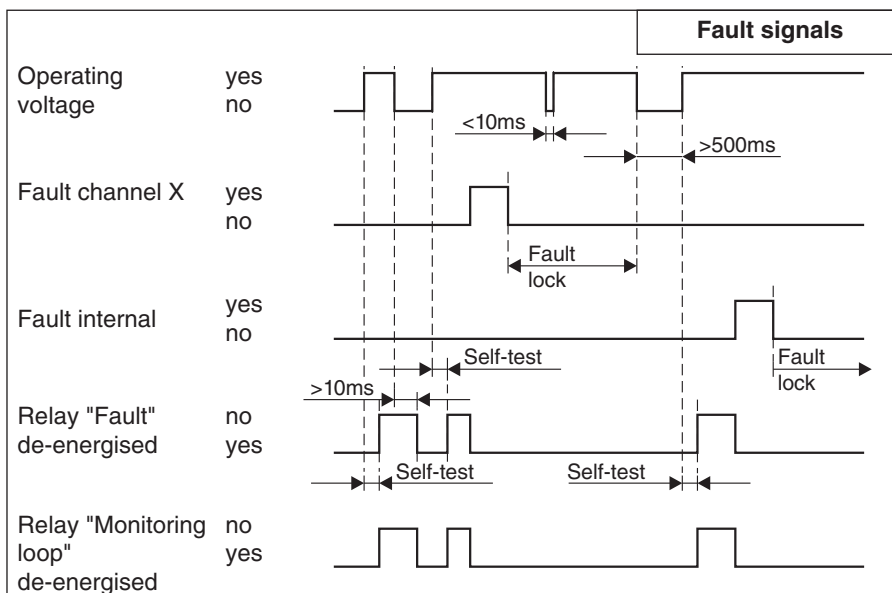

Installation and Operation

LEDs information: start-up test













































Betrieb (on) green	Betätigt Kanal 2 (activated channel 2) yellow	Störung Kanal 2 (fault channel 2) red	Betätigt Kanal 1 (activated channel 1) yellow	Störung Kanal 1 (fault channel 1) red	Störung allg. (general fault) red	Meaning
						LED off: ○ LED on: ☀
○	○	○	○	○	○	No operating voltage
☀	☀	☀	☀	☀	☀	Operating voltage active, LEDs flash briefly, start 1st Start-up test
○	○	○	○	○	☀	1. Start-up test: after 0.1 sec
○	○	○	○	☀	☀	1. Start-up test: after 0.7 sec
○	○	○	☀	☀	☀	1. Start-up test: after 1.3 sec
○	○	☀	☀	☀	☀	1. Start-up test: after 1.9 sec
☀	☀	☀	☀	☀	☀	Operating voltage active, LEDs flash briefly, start 2nd Start-up test
☀	○	☀	○	☀	○	2. Start-up test: 1st RAM-test
○	☀	○	☀	○	☀	2. Start-up test: 2nd RAM-test
☀	☀	○	○	☀	☀	2. Start-up test: ROM-test
☀	○	○	○	○	○	Start-up test ended, Control Unit ready

LEDs information: Operation







































Betrieb (on) green	Betätigt Kanal 2 (activated channel 2) yellow	Störung Kanal 2 (fault channel 2) red	Betätigt Kanal 1 (activated channel 1) yellow	Störung Kanal 1 (fault channel 1) red	Störung allg. (general fault) red	Meaning
						LED off: ○ LED on: ☀
☀	○	○	○	○	○	Operating voltage active, Control Unit ready
☀	○	○	☀	○	○	Sensor 1 activated, relay "activated" and relay "monitoring loop" de-energised – depending on train signals
☀	☀	○	○	○	○	Sensor 2 activated, relay "activated" and relay "monitoring loop" de-energised – depending on train signals
☀	☀	○	☀	○	○	Sensors 1 and 2 activated

Maintenance and troubleshooting

LEDs information: Fault code start-up test

Betrieb (on) green	Betätigt Kanal 2 (activated channel 2) yellow	Störung Kanal 2 (fault channel 2) red	Betätigt Kanal 1 (activated channel 1) yellow	Störung Kanal 1 (fault channel 1) red	Störung allg. (general fault) red	Meaning
						LED off:  LED on: 
						CPU fault
						ADU fault
						Hardware reset fault
						WatchDog fault
						Fault in relay "monitoring loop"
						Fault in RAM-test
						Fault in ROM-test

LEDs information: Fault code operation

Betrieb (on) green	Betätigt Kanal 2 (activated channel 2) yellow	Störung Kanal 2 (fault channel 2) red	Betätigt Kanal 1 (activated channel 1) yellow	Störung Kanal 1 (fault channel 1) red	Störung allg. (general fault) red	Meaning
						LED off:  LED on: 
						ROM-fault
						Fault in relay "monitoring loop"
						Sensor 1: internal fault
						Sensor 2: internal fault
						Sensor 1: cable break, relay "fault" and relay "monitoring loop" de-energised
						Sensor 2: cable break, relay "fault" and relay "monitoring loop" de-energised

Maintenance and troubleshooting

Maintenance

The Control Unit is maintenance-free.
If no shorter testing intervals are specified, check the safety system monthly **in the following order**:

1. Unit still switched off

Relay "fault" (13, 14), relay "activated" (23, 24) and relay "monitoring loop" (33, 34) must have de-energised.

2. Switch unit on

Relay "fault" (13, 14) and relay "activated" (23, 24) must energise.

3. Activate sensor

Relay "activated" (23, 24) must de-energise.

Troubleshooting and remedies

Prerequisite: Control Unit SG-RSV 2X9 connected to power supply and sensor(s).

Sensor not activated and Control Unit does not respond:

- LED "Betrieb" (on) not lit
 - > Supply voltage off or incorrect.
 - ☞ Check supply voltage, compare with type plate.
 - ☞ Observe correct polarity.
 - > Fault still exists: Control Unit faulty.
 - ☞ Replace Control Unit.

Sensor not activated and relay "Fault" not energised:

- LED "Störung Kanal X" (fault channel X) lit
 - > Sensor or supply lines faulty (connection interrupted).
 - ☞ Check sensor with gauge: set value = $1k\Omega \pm 2\%$.
 - > Actual value \neq set value: sensor or supply line faulty.
 - ☞ Replace sensor.
 - LED "Störung Kanal X" (fault channel X) not lit
 - > Control Unit faulty.
 - ☞ Connect resistor $1k\Omega$ instead of the sensor.
 - > Fault still exists: Control Unit faulty.
 - ☞ Replace Control Unit.

Sensor interrupted and relay "fault" not de-energised:

- > Control Unit faulty.
 - ☞ Disconnect sensor.
 - > Relay "fault" not deenergised: Control Unit faulty.
 - ☞ Replace Control Unit.

Sensor not activated and relay "activated" not energised:

- LED "Betätigt Kanal X" (activated channel X) lit
 - > Sensor or supply line faulty (short-circuit).
 - ☞ Check sensor with gauge: set value = $1k\Omega \pm 2\%$.
 - > Actual value \neq set value: sensor or supply line faulty.
 - ☞ Replace sensor.
 - LED "Betätigt Kanal X" (activated channel X) not lit
 - > Control Unit faulty.
 - ☞ Connect resistor $1k\Omega$ instead of the sensor.
 - > Fault still exists: Control Unit faulty.
 - ☞ Replace Control Unit.

Sensor actuated and relay "activated" not de-energised:

- LED "Betätigt Kanal X" (activated channel X) not lit
 - > Sensor or supply line faulty (resistance change too low).
 - ☞ Check sensor with gauge: set value "activated" < 300 Ohm.
 - > Actual value > 300 Ohm : sensor or supply line faulty.
 - ☞ Replace sensor.
 - > Control Unit faulty.
 - ☞ Test sensor with gauge: set value "activated" < 300 Ohm.
 - > Actual value < 300 Ohm : Control Unit faulty.
 - ☞ Replace Control Unit.

LED "Störung allg." (general fault) lit:

- > Control Unit faulty.
 - ☞ Replace Control Unit.

Fault can still not be detected? - Mayser Support will help: tel. +49 731 2061-0