

MAYSER®

Polymer Electric

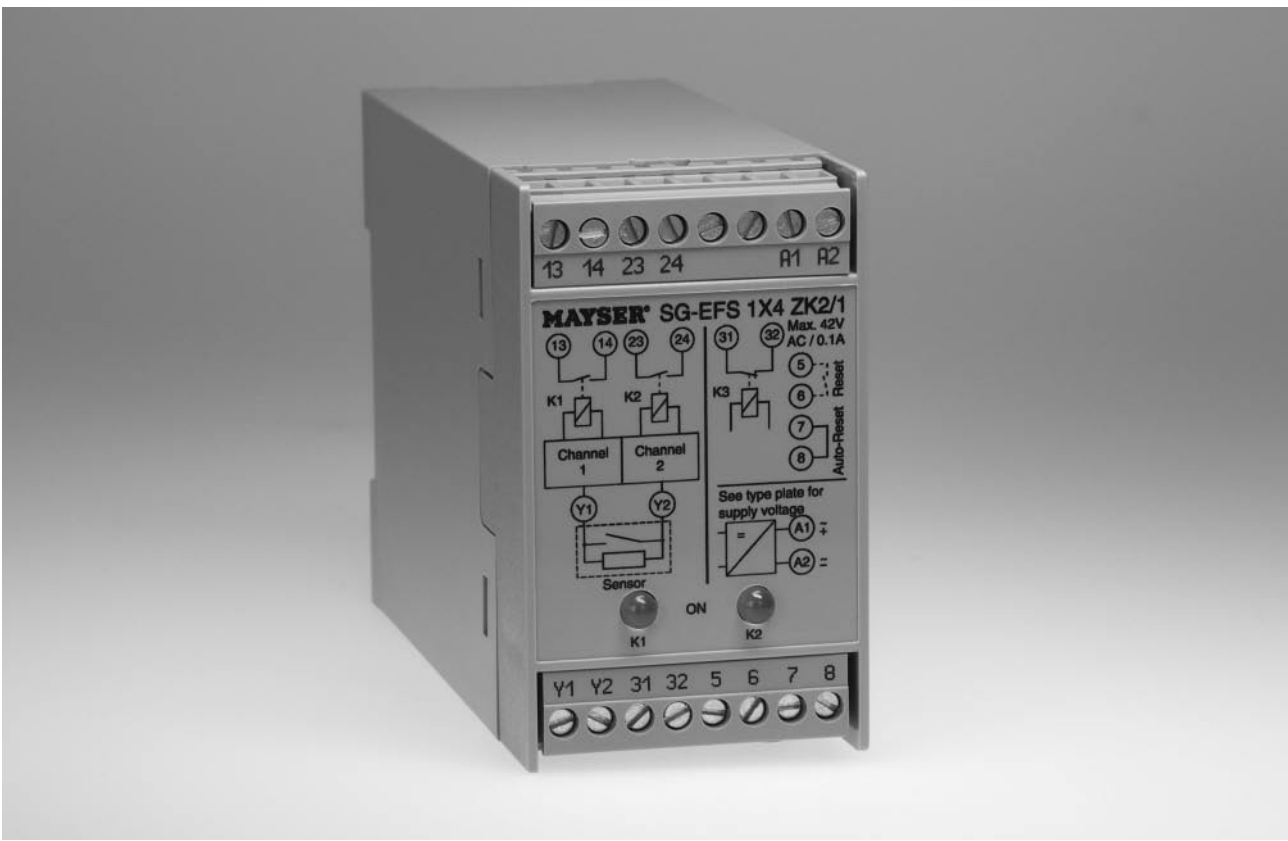

Operating Instructions



Control Unit SG-EFS 1X4 ZK2/1

Version 3.0

1000841	SG-EFS 104 ZK2/1	24 V=~/~
1001272	SG-EFS 114 ZK2/1	115 V~
1000842	SG-EFS 134 ZK2/1	230 V~

MAYSER® GmbH & Co. KG
Polymer Electric
Örlinger Straße 1–3
89073 Ulm
GERMANY
Tel.: +49 731 2061-0
Fax: +49 731 2061-222
E-Mail: info.ulm@mayser.de
Internet: www.mayser.com

Original instructions

Contents

About these operating instructions	3
Intended use	4
Safety instructions	4
Parts supplied	5
Transport and storage	6
Packaging and transport	6
Storage.....	6
Product overview	6
Connections	6
LEDs information.....	6
Operation, installation and commissioning	7
Operation.....	7
Installation	7
Automatic reset	8
Manual reset	9
Commissioning.....	9
Test function: automatic reset.....	9
Test function: manual reset.....	10
Recommissioning	10
Automatic reset	10
Manual reset	10
Recommissioning	11
Contacts continued in two-channel mode	11
Contact duplication for automatic reset.....	11
Contact duplication for manual reset.....	11
Maintenance and cleaning	12
Maintenance.....	12
Cleaning	12
Troubleshooting and remedies	13
Replacement parts	13
Disposal	13
Conformity	14
EC Design Test	14
UL certification	14
Technical Data	14

Copyright

The reproduction, distribution and utilization of this document as well as the communication of its contents without express authorization is prohibited. Offenders will be held liable for the payment of damages. All rights reserved in the event of the grant of a patent, utility model or design.

© Mayser Ulm 2011

About these operating instructions

These operating instructions are part of the product.

Mayser Polymer Electric accepts no responsibility or warranty claims for damage and consequential damage due to failure to observe the operating instructions.

- ➔ Read operating instructions carefully before use.
- ➔ Keep operating instructions for the complete service life of the product.
- ➔ Pass operating instructions on to every subsequent owner or user of the product.
- ➔ Add any supplement received from the manufacturer to the operating instructions.

Validity

These operating instructions are only valid for the products specified on the title page.

Target group

The target group of these operating instructions are operators and trained specialist personnel who are familiar with installation and commissioning.



Other applicable documents

- ➔ In addition to the operating instructions, observe the following documents:
 - Drawing of the sensor system (optional)
 - Wiring diagram (optional)
 - Installation instructions of the sensors used

Symbols used

Symbol	Meaning
➔ ...	Action with one step or with more than one step where the order is not relevant.
1. ... 2. ... 3. ...	Action with more than one step where the order is relevant.
• ...	Bullets first level
- ...	Bullets second level
(see <i>Assembly</i>)	Cross-reference

Danger symbols and information

Symbol	Meaning
DANGER 	Immediate danger leading to death or serious injury.
CAUTION 	Possible danger which may lead to slight injury or damage to property.
	Information on easier or safer working practices.

Intended use

The Control Unit is designed for signal processing of a pressure-sensitive protective device (PSPD). It evaluates the output signals of sensors with monitoring resistor 8k Ω . The integrated output signal switching device (OSSD) transmits the evaluated safety signals directly to the downstream machine controls. The Control Unit complies with ISO 13849-1:2006 Category 3 PL d. So that the safety classification is retained, the forwarding control must be of the same or a higher category.

Safety instructions

- ➔ **Do not open the control unit**
Never open, tamper with or alter the Control Unit.
- ➔ **Check supply voltage**
Check supply voltage. It must correspond with the connecting voltage U_s on the type plate.
- ➔ **Observe protection class**
Only use the Control Unit in rooms with a minimum degree of protection of IP54 (e.g. switch cabinet).
- ➔ **Maintain distance**
When installing in the switch cabinet, ensure sufficient distance from heat sources (at least 2 cm).

- ➔ **Observe pin assignment**
Observe pin assignment when connecting the supply voltage.

- ➔ **Protect relay contacts**
Risk of welding: Protect the relay contacts externally.

- ➔ **Fit spark absorbers**
When connecting inductive loads, fit spark absorbers (RC modules) to the consumer.

- ➔ **Do not cross link Control Unit**
Do not cross link the Control Unit with other Control Units.
Terminals Y1, Y2 as well as 5, 6 and 7, 8 are not voltage free.

- ➔ **Do not overload Control Unit**
Ensure that the specified switching current is not exceeded.

- ➔ **Continue redundancy**
Make sure you wire the unit directly in the control circuit or that the downstream control is also in dual channel mode.

- ➔ **In the event of a fault, put out of operation**
In the event of malfunctions and visible damage, put the Control Unit out of operation.

- ➔ **Do not use in ATEX zones**
Do not use the Control Unit in potentially explosive environments (ATEX). The Control Unit is not authorised for use in these zones.

Parts supplied

1× Control Unit

Enclosure with electronics module and plug-in connectors.

1× Operating Instructions

1× Declaration of Conformity

Check the scope of supply for completeness and the perfect condition of the product immediately after receipt.

Transport and storage

Packaging and transport

The Control Units are packed individually in cardboard boxes. Several Control Units are stacked in one large cardboard box.

The documents are enclosed separately.

Storage

- ➔ Store the Control Units in the original packaging in a dry place.
- ➔ Observe the storage temperatures given in the technical specifications.

Product overview

Connections

Connections:	Terminals:
Supply voltage	A1, A2
Switching channel 1 (Channel 1)	13, 14
Switching channel 2 (Channel 2)	23, 24
Signal circuit	31, 32
Reset	5, 6
Auto-Reset	7, 8
Sensor	Y1, Y2

LEDs information

- yellow LED "K1 ON":
Sensor not activated
- yellow LED "K2 ON":
Sensor not activated

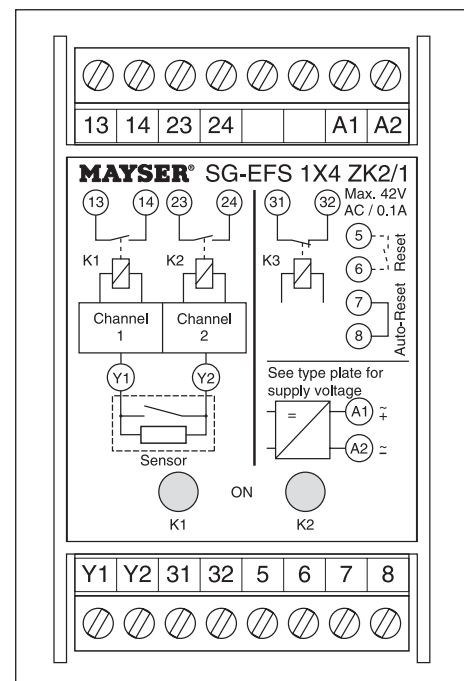

Operation, installation and commissioning

Operation

The single-fault-safe electronics module has dual channels (redundant). Each channel controls a forceguided relay and additionally monitors the relay of the other channel. The electronic system monitors the electrical resistance of the sensor with a defined zero signal current. When the sensor is not actuated and after a reset, the relays K1 and K2 are energised. The yellow LEDs "K1 ON" and "K2 ON" light up, the switch channels 1 and 2 are closed and the signal circuit is open. When the sensor is actuated, the K1 and K2 relays are de-energised. The yellow LEDs "K1 ON" and "K2 ON" go out, the switch channels 1 and 2 are open, and the signal circuit is closed. If the sensor cable breaks, relays K1 and K2 are de-energised. The yellow LEDs "K1 ON" and "K2 ON" go out, the switch channels 1 and 2 are open, and the signal circuit is closed. The signal circuit works opposed to the switch channels 1 and 2.

Installation

DANGER



Danger of injury due to electrocution!

- ➔ Disconnect all devices and live parts in the immediate environment of the power supply and protect them against being switched on again (see relevant operating instructions)
 - ➔ Check whether all devices and parts are disconnected from the power supply
-

CAUTION



Impaired operation due to overheating

The operation of the protective device may be impaired due to overheating of the Control Unit.

- ➔ When installing in the switch cabinet, ensure sufficient distance from heat sources (at least 2 cm)
-

1. The enclosure of the Control Unit can be mounted in any position on a 35 mm IEC 60175 rail

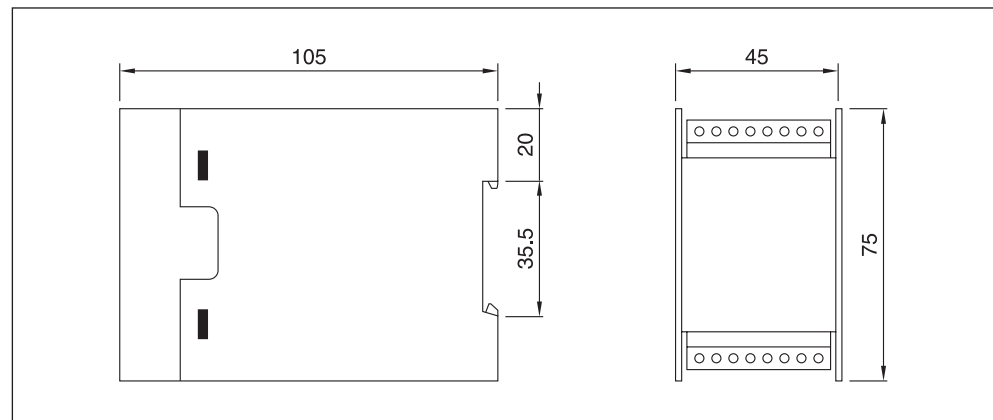

DANGER



Overall safety endangered

The quality and reliability of the interface between the protective device and the machine influences the overall safety.

➔ Install the interface very carefully

2. Wire the sensors, switching channels, signal circuit and supply voltage to the terminals.

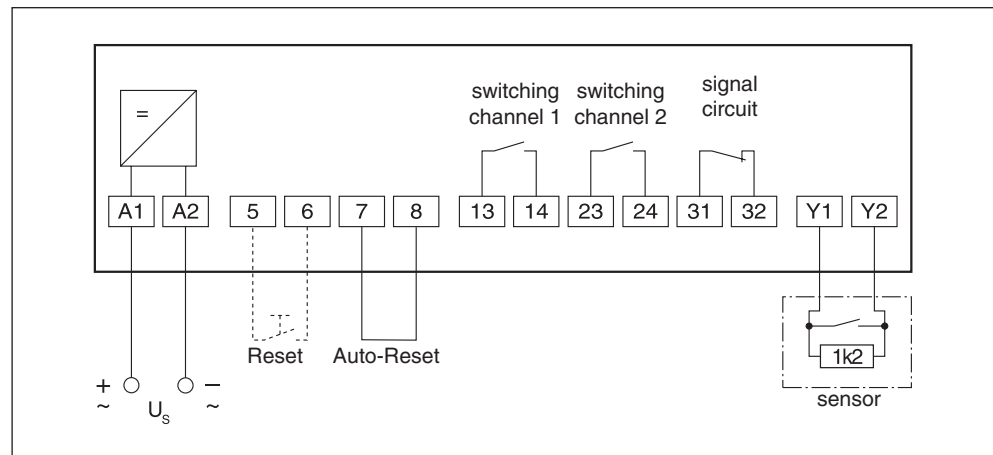

Automatic reset

A bridge is necessary for automatic reset (without reset command). The unit is supplied with a bridge already connected between cable terminals 7 and 8

➔ Check if the bridge is set between cable terminals 7 and 8.

Manual reset

For manual reset (with reset command), a switch must be connected between cable terminals 5 and 6. The control unit reacts when the switch changes from “not activated” to “activated”, i.e. if the switch sticks, no reset command is initialised.

- ➔ Remove the bridge between cable terminals 7 and 8.
- ➔ Wire up a switch between cable terminals 5 and 6.

Commissioning

1. Make sure the plug connections are firmly attached.
2. Connect the supply voltage.

DANGER



Danger of injury due to electrocution!

- ➔ Never disconnect terminals with the power on
 - ➔ Never unplug plug connections with the power on.
-

Test function: automatic reset

1. Make sure no sensors are activated.
 - yellow LEDs “K1 ON” and “K2 ON” are lit up
 - contacts of switch channels 1 and 2 closed
 - signal circuit open
2. Activate a sensor.
 - yellow LEDs “K1 ON” and “K2 ON” go out
 - contacts of switch channels 1 and 2 open
 - signal circuit closed
3. Repeat step 1.
4. Disconnect the sensor.
 - yellow LEDs “K1 ON” and “K2 ON” go out
 - contacts of switch channels 1 and 2 open
 - signal circuit closed

Test function: manual reset

1. Make sure no sensors are activated.
 - yellow LEDs "K1 ON" and "K2 ON" are not lit up
 - contacts of switch channels 1 and 2 open
 - signal circuit closed
2. Activate the reset switch.
 - yellow LEDs "K1 ON" and "K2 ON" are lit up
 - contacts of switch channels 1 and 2 closed
 - signal circuit open
3. Activate a sensor.
 - yellow LEDs "K1 ON" and "K2 ON" go out
 - contacts of switch channels 1 and 2 open
 - signal circuit closed
4. repeat steps 1 and 2.
5. Disconnect the sensor.
 - yellow LEDs "K1 ON" and "K2 ON" go out
 - contacts of switch channels 1 and 2 open
 - signal circuit closed

Recommissioning

DANGER



Danger of injury!

- ➔ Never start your machine as long as the danger remains.
-

Automatic reset

The Control Unit works without a reset command. When the sensor is released after actuation, the relays K1 and K2 are re-energised after a delay t_w

- ➔ Check for proper functioning after recommissioning (see section *Commissioning*)

Manual reset

The Control Unit works with a reset command. Relays K1 and K2 are only energised after the reset switch is actuated.

- ➔ Check for proper functioning after recommissioning (see section *Commissioning*)

Recommissioning

Contacts continued in two-channel mode

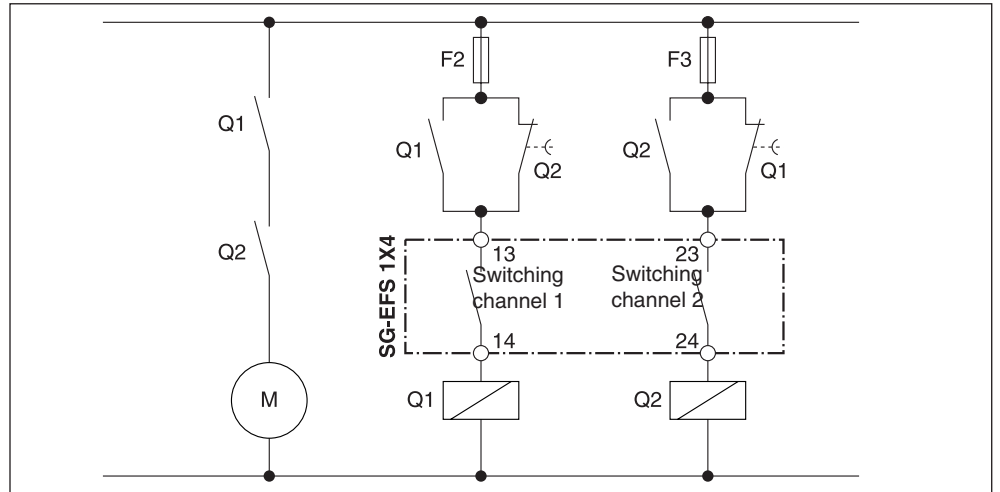

Contact duplication for automatic reset

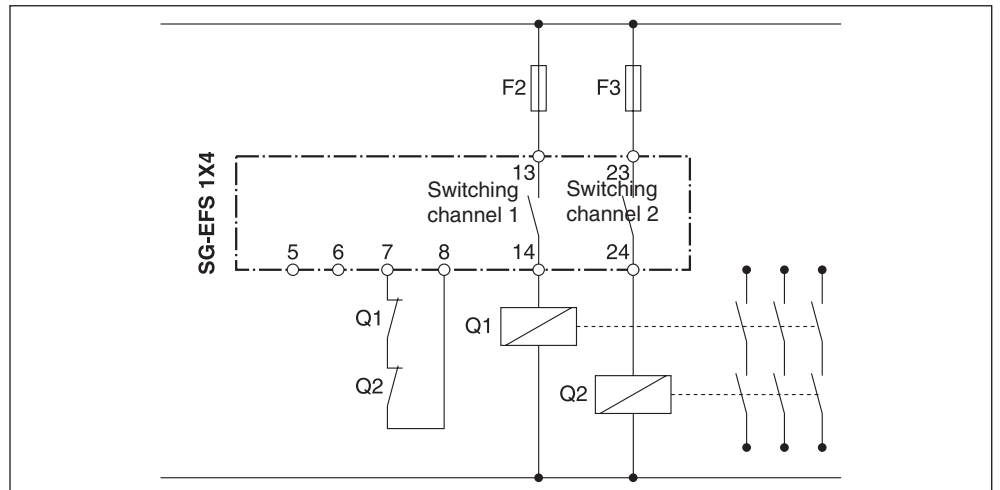

Contact duplication for manual reset

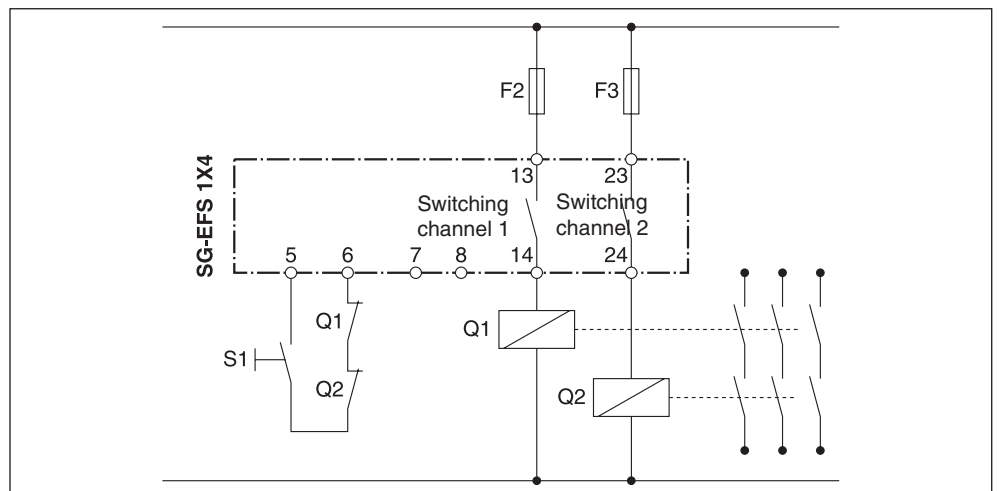

Maintenance and cleaning

Maintenance

The Control Unit is maintenance-free.

- ➔ Repeat the operational test monthly.

Cleaning

DANGER



Danger of injury due to electrocution!

- ➔ Disconnect the Control Unit as well as all devices and live parts in the immediate environment of the power supply and protect them against being switched on again (see relevant operating instructions).
 - ➔ Check whether all devices and parts are disconnected from the power supply.
-
- ➔ Clean the outside of the enclosure with a dry cloth.

Troubleshooting and remedies

Prerequisite: The Control Unit is connected to the supply voltage and sensor. The sensor is not activated.

Fault display	Possible cause	Remedy
yellow LEDs "K1 ON" and "K2 ON" do not light	Supply voltage off or incorrect	1. Check supply voltage, compare with type plate. 2. Check terminal connections
	Incorrect monitoring resistor on sensor	➔ Connect sensor with monitoring resistor 1k2
	If monitoring resistor is correct: sensor is faulty	➔ Replace sensor
	No sensor connected	➔ Connect sensor
	Sensor incorrectly connected	➔ Check terminal connections
	Cable break	➔ Replace sensor
	Manual reset: reset switch not actuated	➔ Actuate reset switch
	Manual reset: reset switch sticks	➔ Replace switches on terminals 5 and 6
	Automatic reset: bridge missing	➔ Connect bridge between terminals 7 and 8
Only one LED lights up	Control Unit is faulty	➔ Replace Control Unit
	Incorrect supply voltage	➔ Check supply voltage, compare with type plate.
	Control Unit is faulty	➔ Replace Control Unit

Fault can still not be detected?

➔ Contact Mayser-Support: Tel. +49 731 2061-0.

Replacement parts

CAUTION



Overall safety endangered

If the sensor and Control Unit are not replaced with original parts from Mayser, operation of the protective device may be impaired.

➔ Only use original parts from Mayser.

Disposal

The Control Units produced by Mayser are professional electronic tools exclusively intended for commercial use (so-called B2B devices). Unlike devices mainly used in private households (B2C), they may not be disposed of at the collection centres of public sector disposal organisations (e.g. municipal recycling depots). At the end of their useful life, the devices may be returned to us for disposal.

WEEE reg. no. DE 39141253

Conformity



The design type of the product complies with the basic requirements of the following directives:

- 2006/42/EC (Safety of Machinery)
- 2004/108/EC (EMC)
- 2006/95/EC (Low voltage)

The Declaration of Conformity is available in the Downloads section of the website:
www.mayser-sicherheitstechnik.de

EC Design Test

The product was tested by an independent institute.
An EC design type test certificate confirms conformity.

The EC design type test certificate is available in the Downloads section of the website:

www.mayser-sicherheitstechnik.de

UL certification



The design type of the product conforms with the basic requirements of:
UL certification

- UL 508

Technical Data

SG-EFS 1X4 ZK2/1	AC/DC 24 V	AC 115/230 V
Test principles	EN 1760-1, EN 1760-2, EN 1760-3, EN 12978 , ISO 13849-1	
Supply voltage U_s		
Voltage tolerance	-15% to +10% / -15% to +20%	-15% to +10%
Nominal current	192 mA / 89 mA	48 mA / 28 mA
Nominal frequency	48 to 62 Hz / –	48 to 62 Hz
External protection	250 mA T	250 mA T
Power consumption	< 5 VA / < 3 W	< 7 VA
Times		
Reaction time t_a	< 10 ms	< 10 ms
Re-start time t_w	< 190 ms	< 190 ms

SG-EFS 1X4 ZK2/1	AC/DC 24 V	AC 115/230 V
Safety classifications		
EN 1760: Reset ISO 13849-1:2006 MTTF _d DC _{avg} B _{10d} (Load: DC 24 V / 2 A) n _{op} (estimate) CCF EN 60664-1: Creep distance and air gap	with/without Category 3 PL d 313.3 years 90% 2× 10 ⁶ 52560 per year Requirements fulfilled soiling degree 2, overvoltage category II / 230 V, basic insulation	with/without Category 3 PL d 313.3 years 90% 2× 10 ⁶ 52560 per year Requirements fulfilled soiling degree 2, overvoltage category II / 230 V, basic insulation
Control Unit Inputs		
Sensor Monitoring resistor Short-circuit resistance Line resistance Line length (max.) Switching thresholds Sensor activated Cable break	Y1, Y2 1k2 Ohm ≤ 400 Ohm ≤ 100 Ohm 100 m < 600 Ohm > 1k8 Ohm	Y1, Y2 1k2 Ohm ≤ 400 Ohm ≤ 100 Ohm 100 m < 600 Ohm > 1k8 Ohm
Control Unit Outputs		
Switching channel 1 and 2 (NO contact) Utilization category as per EN 60947-5-1 Switching voltage (max.) Switching current (max.) Switching current (min) Switching capacity (max.) Switching operations, mechanical Switching operations, electrical Contact fuse protection external Signal circuit (NC contact) Switching voltage (max.) Switching current (max.) Switching operations, mechanical Switching operations, electrical Contact fuse protection external	13, 14 / 23, 24 AC-12: 250 V / 2 A DC-12: 24 V / 2 A AC 250 V DC 24 V 2 A 2 A 10 mA 10 mA 500 VA 48 W > 5× 10 ⁷ > 3× 10 ⁵ (AC 250 V / 2 A) 2 A quick-acting 31, 32 AC 42 V DC 42 V 100 mA 100 mA > 5× 10 ⁶ > 1× 10 ⁶ (AC 42 V) 0.1 A quick-acting	13, 14 / 23, 24 AC-12: 250 V / 2 A DC-12: 24 V / 2 A AC 250 V DC 24 V 2 A 2 A 10 mA 10 mA 500 VA 48 W > 5× 10 ⁷ > 3× 10 ⁵ (AC 250 V / 2 A) 2 A quick-acting 31, 32 AC 42 V DC 42 V 100 mA 100 mA > 5× 10 ⁶ > 1× 10 ⁶ (AC 42 V) 0.1 A quick-acting
Mechanical operating conditions		
Cable terminals solid wire strand without sheath strand with sheath Degree of protection as per IEC 60529 max. humidity (23 °C) Operating temperature Storage temperature Impact resistance in operation Impact resistance transport Dimensions (W × H × D) Weight	1× 2.5 mm ² or 2× 1 mm ² 1× 2.5 mm ² or 2× 1.5 mm ² 1× 2.5 mm ² or 2× 1 mm ² IP20 95% -20 °C to +50 °C -20 °C to +50 °C 2.5 g 10 g 45 × 75 × 105 mm 180 g	1× 2.5 mm ² or 2× 1 mm ² 1× 2.5 mm ² or 2× 1.5 mm ² 1× 2.5 mm ² or 2× 1 mm ² IP20 95% -20 °C to +50 °C -20 °C to +50 °C 2.5 g 10 g 45 × 75 × 105 mm 282 g